

Processing instructions

EGGER Worktop wall profile

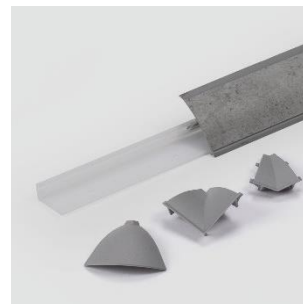

EGGER Worktop wall profiles provide a visually harmonious and functional connection between EGGER worktops and the wall. The EGGER coordinated range of colours plus the matching shaped parts and sealing lips create unity in colour and design. EGGER wall end profiles are easy to apply and fit.

Profiles

EGGER Worktop wall profiles have two parts and consist of a base and upper profile:

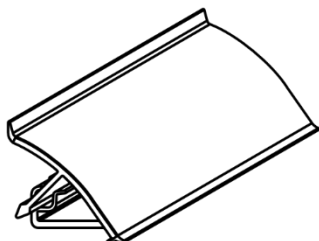

Base profile with upper profile

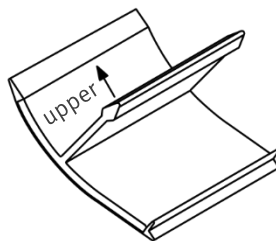

Upper profile

In addition to decorative aspects, the upper profile also has a protective function due to the integrated upper sealing lip and the double sealing lip in the lower area as a supporting edge.

Shaped parts

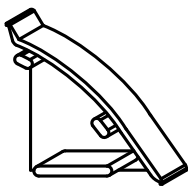

End caps left/right

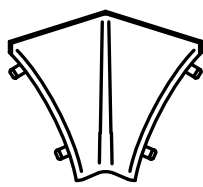

Internal corner 90°

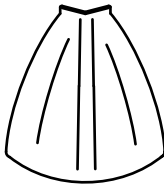

External corner 90°

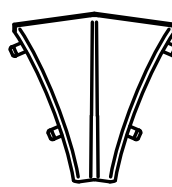

Internal corner 135°

The various shaped parts match the sealing lips in terms of colour.

Processing

Before fitting the wall profiles to the worktop, the long back edge and all transverse edges which connect to a wall must be sealed. EGGER Worktop wall profiles can be processed quickly in a few simple steps. To ensure a flawless finish, proceed in the following sequence:

1. After measuring, the base and upper profiles are cut at right angles to the required length. Take the returns into account when measuring. Take the appropriate measurements from the illustrations below.
2. When attaching the base profile, ensure that the worktop surface is predrilled in the screw fastening area. The holes must be at least 1 mm larger than the screw diameter to prevent stresses building up in the material. We also recommend protecting the inside of the screw hole with sealant before screwing.
3. Screw the base profile to the worktop.
 Ensure that the hole separation from the end is no more than 20 mm and that the base profile is seated correctly against the wall. Countersunk screws must not be used for installation. Here, Spax round head screws with full thread 3 x 15 mm (seven items per meter) are recommended.

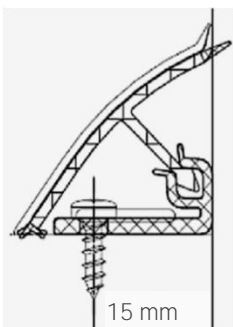

Screwing base profile

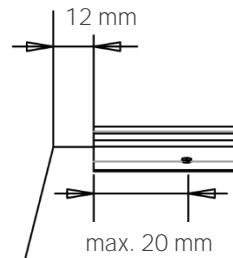
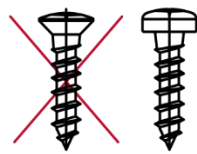

Fixing dimensions base profile

4. The upper profile is attached to the base profile and pressed in. If necessary use a hammer plus wooden block. In the process, the double sealing lip must rest on the worktop and the single sealing lip must face upwards.
5. Start the assembly of the upper profile at an internal corner. Attach the shaped part for the internal corner (90° or 135°) on the upper profile and start with the assembly in the corresponding corner. Before the upper profile engages completely into the base profile up to another corner, the next shaped part is attached first.
6. Attach end caps left and right on the profile ends.

Returns

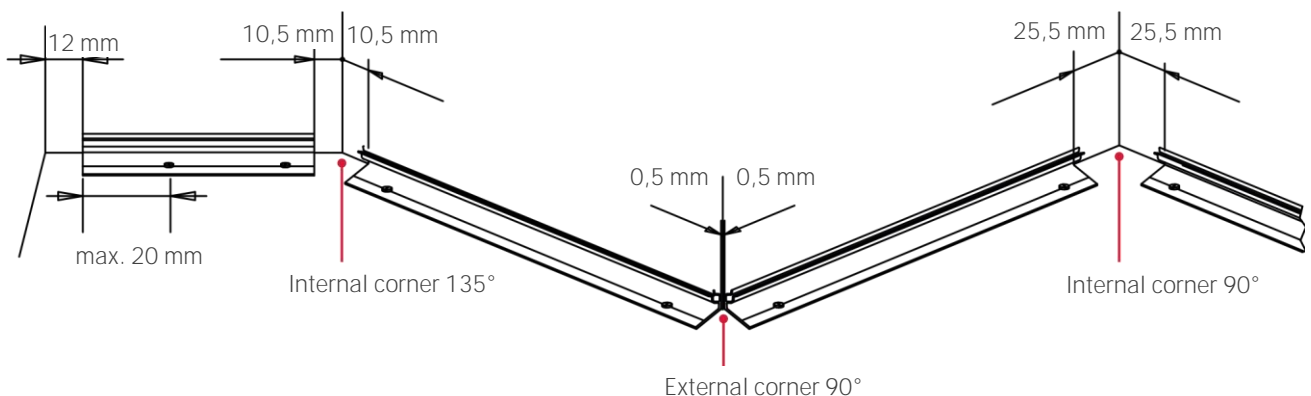

Base profile

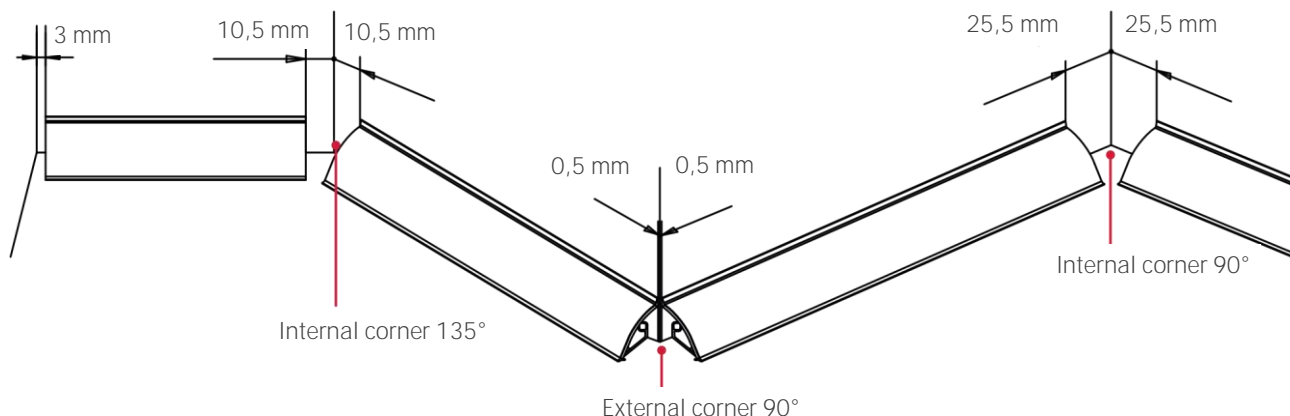

Upper profile

Please note: EGGER Worktop wall profiles, shaped parts and sealing lips have a temperature resistance of 70°C. Gas ovens or open flame gas cookers will exceed this temperature on the outside edge of the pan base. To ensure the wall end profile is not exposed to heat damage, we recommend a safety margin of 3 cm between the rear edge of the pan and the front edge of the wall end profile. For electric hobs, follow the manufacturer’s installation instructions.

Cleaning recommendations

Clean the decor surfaces and sealing lips with a household cleaner or mild cleaning agent. If the use of an undiluted cleaner is required, the surface should be immediately wiped with clear water afterwards. Strong aggressive solvents, such as thinners, acetone or MEK are not permitted, as they can result in damage to the decor or material.

For further information please see the processing instructions “EGGER worktops”.

Additional documents / Product information

You will find further information in the following documents:

- Processing Instructions “EGGER Worktops”
- Technical leaflet “EGGER Worktop wall profile”

Provisional note:

These processing instructions have been carefully drawn up to the best of our knowledge. The information provided is based on practical experience, in-house testing and reflects our current level of knowledge. It is intended for information only and does not constitute a guarantee in terms of product properties or its suitability for specific applications. We accept no liability for any mistakes, errors in standards, or printing errors. In addition, technical modifications may result from the continuous development of EGGER Worktop wall profiles, as well as from changes to standards and public law documents. The contents of these processing instructions should therefore not be considered as instructions for use or as legally binding. Our General Terms and Conditions apply.