

TECHNICAL DATA SHEET

EGGER WINDOW SILLS



EGGER window sills are composite elements consisting of EUROSPAN® E1 raw chipboard, with the surface and profiles being seamlessly laminated with decorative EGGER laminate flex. The back long edge of the window sill is laminated with melamine edging to protect against moisture.

Applications / Application Areas

EGGER window sills are the ideal solution for conversions, new construction and renovations. They are practical, robust and offer an attractive choice of decors. In lengths of 4,100 and 5,200 mm, the sills are convenient to cut, and allow for the seamless joining of wide window fronts.

Storage / Fabrication

STORAGE

Horizontal, flat storage in closed and dry rooms (approx. 20°C and 55 to 65% relative humidity) is required, in order to exclude climate-conditioned warping or dimensional changes. Vertical storage is not permissible. In order to avoid storage damage, appropriate shelving systems must be used exclusively. Care needs to be taken when relocating the window sills.

CONDITIONING

As window sills can dimensionally change due to climate changes, they should be stored and processed in conditions corresponding to those they will be installed in. Prior to the installation of window sills, they should be conditioned for a few days in the respective rooms under the subsequent conditions of use. Compliance with the storage recommendations is required on construction sites as well.

PROCESSING

EGGER window sills can be processed on normal woodworking machines. Whatever they encounter on a daily basis, the surfaces will retain their high performance characteristics providing that the recommendations on processing and assembly are followed.

For further information, please consult the processing instructions “EGGER Window Sills”.

Quality features / Technical data

The quality characteristics of EGGER window sills are achieved mainly through the use of laminate according to EN 438:2005. The laminate flex used for the production of window sills is classified as HGP (horizontal general-purpose post-forming). For the most important quality characteristics such as surface abrasion, shock resistance and scratch resistance, HGP means that high resistance is required which is classified as class 3 under the EN 438 standard.

Property	Testing procedure in accordance with EN 438-2	Unit	Value	Class
Resistance to surface abrasion	10	Revolutions	≥ 350	3
Scratch resistance	25	Grade	3	3
Resistance to impact from a small ball	20	Newtons	≥ 20	3

ADDITIONAL QUALITY FEATURES

Quality feature	Unit	Result	Standard
Resistance to dry heat	Grade	4	EN 438-2:2005
Resistance to water vapour	Grade	4	EN 438-2:2005
Resistance to staining group 1 and 2	Grade	5	EN 438-2:2005
Resistance to staining group 3	Grade	4	EN 438-2:2005
Light fastness (Xenon arc lamp)	Grey scale	4 - 5	EN 438-2:2005
Resistance to cigarette burns	Grade	3	EN 438-2:2005
Swelling behaviour *	-	24 h max. 14 %	DIN EN 317
Bending strength *	N/mm ²	> 12.0	DIN EN 310
Internal bond *	N/mm ²	> 0.40	DIN EN 319
Raw density *	kg/m ³	600 - 720	DIN EN 323
Surface soundness *	N/mm ²	≥ 1.0	DIN EN 311

* The results listed above are mean values for core boards ranging in thickness from 19 mm to 22 mm.

TECHNICAL DATA / TOLERANCES / DIMENSIONS

Coreboards:	EUROSPAN® Rawboards E1 according to EN 312.
Coreboard type:	P3 according to EN 312 or EN 622-5 for use in dry, indoor applications
Coating:	EGGER laminate flex according to EN 438:2005
Laminate thicknesses:	Standard thickness 0.5 mm
Standard length:	4,100 mm and 5,200 mm
Length tolerance:	Standard production articles ± 5 mm
Standard widths:	160 mm, 200 mm, 250 mm, 300 mm, 400 mm and 500 mm
Width tolerance:	± 0.5 mm

- Standard thicknesses: 19 mm 38 mm with false edge and 22 mm – see model sketch
- Thickness tolerance: ± 0.4 mm
- Angular accuracy: 2.0 mm per 1,000 mm side length
- Straightness of cut: 0.5 mm per 1,000 mm side length
- Surface bonding: D3 according to DIN EN 204
- Post-forming bonding: D2 according to DIN EN 204

EGGER window sills are available as standard production articles in standard lengths and widths from the current collections. Individual dimensions and special qualities are manufactured to order.

Terms / Notes / Possible Models

TERMS / NOTES

- EGGER laminate \Rightarrow decorative laminate (CPL continuous pressed laminates) based on curable resins
- Note \Rightarrow details on radiuses and board thicknesses in the sketches, referring to the coreboard.

POSSIBLE MODELS

MODEL 800/6:

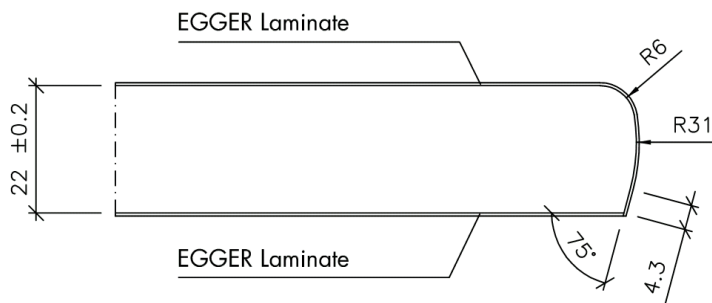

MODEL 801/6:

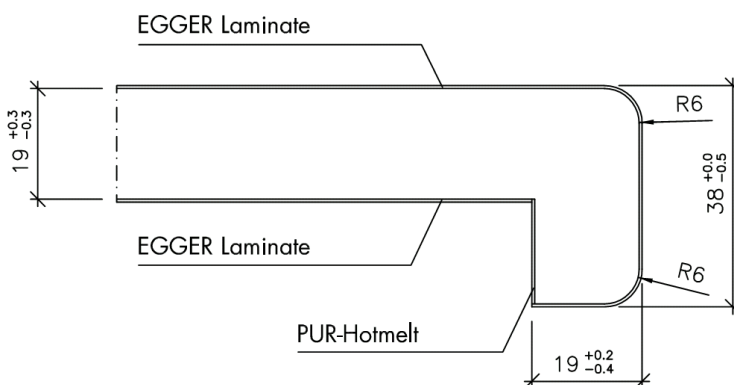

Accessories

Matching EGGER window sill cover caps are available as window sill accessories. With this decorative edging, protecting the narrow surfaces such as end faces and upper edges against moisture is straightforward. Cover caps are available in the colours white, grey and brown.

For further information, please consult the processing instructions “EGGER Window Sills”.



Care and cleaning recommendation

Due to their resistant and hygienic, dense surfaces, EGGER window sills do not require any special form of care. Generally, the surfaces are easy to clean. This also applies to textured surfaces.

For further information, please consult the leaflet “EGGER Laminate Cleaning and Maintenance instructions”.

This Technical Data Sheet has been carefully drawn up to the best of our knowledge. The information provided is based on practical experience as well as in-house tests and reflects our current state of knowledge. It is intended for information only and does not constitute a guarantee in terms of product properties or suitability for specific applications. We accept no liability for any mistakes, errors in standards or printing errors. In addition, technical modifications can result from the continuous further development, as well as from changes in standards and documents originating from statutory bodies. The contents of this Technical Data Sheet should therefore not be considered as instructions for use or as legally binding. Unless otherwise stated, our General Terms and Conditions apply.