

EGGER Advanced Structural Flooring System - Lifetime Guarantee

Be guaranteed for life – use our Advanced boards, Joint & Joist Adhesive and fitting method in combination to be covered by our unique lifetime guarantee*.



* For terms and conditions and further information on the EGGER Advanced Lifetime Guarantee please visit www.egger.com/lifetime

EN_268488_08/18
Subject to technical modifications and amendments.

EGGER (UK) Limited
Anick Grange Road
Hexham, Northumberland
NE46 4JS
United Kingdom

Building Products Hotline

For product, technical advice or general information:

T 0845 602 4444 (charged at local rate)

From R.O.I. please call: T +44 1434 613304

Or email us: building.uk@egger.com

Online technical support

Visit our website for product and technical information: material safety data sheets, technical data sheets, certificates and test reports. www.egger.com/building



Find us on YouTube to view fitting videos, product testing and more.

MORE FROM WOOD.

E EGGER

Fitting Guide



www.egger.com

Fitting Benefits

Faster installations with fewer stoppages

- A quick, straightforward system that's easy to use with less room for errors or mistakes.
- Floors can be installed even in light rain conditions and left exposed to the elements for up to 60 days if using EGGER Protect, and up to 42 days if using EGGER Peel Clean Xtra. (Please note EGGER P5 is for use in dry conditions only).

Save costs

- No need to use joint sealing tapes to cover board joints.
- No requirement for expensive tools or applicator guns.

Fewer call backs and issues after handover

- Developed to vastly reduce squeaks associated with fully nailed floors.
- Comes with a lifetime guarantee when applied correctly using EGGER Advanced boards and EGGER Joint & Joist Adhesive.

Stronger floors

- EGGER Joint & Joist Adhesive is up to five times stronger than a nailed fixing.
- Manufactured using diamond tipped tooling to ensure tight, highly consistent tongue & groove joints.

The EGGER Advanced Range



Fitting Method

Suitable for use with solid timber joists and engineered joists. Please follow joist manufacturers' recommendations in conjunction with fitting EGGER flooring grade chipboard.

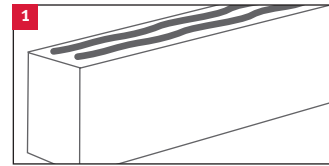

Apply two parallel beads of EGGER Joint & Joist Adhesive to the top of the joist along the first row of boards.

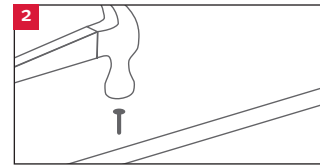

Lay the boards across the joist and fix the first row of boards with only one mechanical fixing (2.5 times the board thickness) per joist from the board edge.

All exposed fitting heads must be sealed with EGGER Joint & Joist Adhesive to prevent potential moisture ingress.

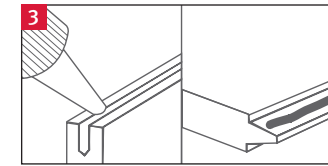

Apply EGGER Joint & Joist Adhesive directly to the groove and shoulder of the profile joint, continuing down the length of each board to ensure that the entire joint is bonded once the boards are butted tightly together. Adhesive should foam out of the board joint - this will enhance the protection of the joint. Excess adhesive should be left to dry.

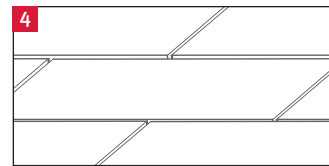

Apply EGGER Joint & Joist Adhesive along the next row of joists and stagger the next row of panels by approximately half a board to form a brick bond laying pattern. Repeat steps (excluding step 2) and note that care should be taken when walking on newly laid boards.

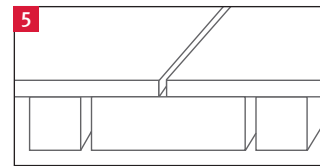

All short end joints should always fall on the centre of a secured joist including perimeter edges. Where this is not the case refer to NHBC guidelines.

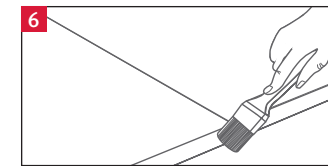

Exposed fitting heads, perimeter edges, cut edges and stairwells must be sealed using EGGER Joint & Joist Adhesive.

Once the building is watertight, excess adhesive can be removed with a scraper.

Fitting Notes

Joist Centres

On joists up to 450 mm centres, 18 mm or 22 mm panels may be used, but on joists up to 600 mm centres 22 mm panels must be used.

Expansion Provision

An expansion gap of 10 mm or 2 mm per metre run of floor, whichever is greater, should be left against all walls. Intermediate gaps (min. 10 mm) should be incorporated for floors in excess of 10 m long e.g. corridors.

Mechanical Fixings

If additional mechanical fixings are used, all exposed fitting heads must be sealed as in step 2.

Adhesive Coverage

Bonding the board to the joist and within the tongue & groove joint will typically require 1 bottle of EGGER Joint & Joist Adhesive per 6 boards (2400 mm × 600 mm).