

MORE FROM WOOD.



PROFESSIONAL



## RAPID DECK FLOOR LAYING SYSTEM

### › Installation instructions

General points to note prior to laying flooring using the Rapid Deck Floor Laying System



The BBA approved **Rapid Deck Floor Laying System** involves bonding EGGER Protect board to the joists and into the tongue and groove of the board using EGGER D4 Adhesive. Designed primarily to reduce installation times and also minimise squeaking floors, whilst complying with current HSE regulations for floor decking.

## BENEFITS

- Complies with current HSE regulations for floor decking
- Saves time and labour costs
- No taping over joints
- Quick and easy to lay
- No need for tools or applicators
- Reduction in time consuming nailing
- Certified by BBA for installation during light rain
- Vastly reduces squeaks often associated with fully nailed floors
- Up to five times stronger than a nailed fixing\*
- Can be left exposed to the elements for up to 42 days once laid
- Negates the requirement for an additional vapour barrier (VCL)

\*The board/joist connection and the tongue and groove joints of the Rapid Deck Floor Laying System have been tested at Durham University in April 2005, to confirm its suitability as a decking solution.

EGGER P5 particleboard is manufactured to EN 312-5:2003 under an ISO 9001:2008 Quality Management System OQS Certificate number 184/0.

The Rapid Deck Floor Laying System is suitable for use with EGGER Protect, EGGER Peel Clean Xtra and EGGER P5 T&G. All of these products incorporate EGGER P5 particleboard which is CE-certified through WKI of Germany CPD-0765-366.

## PREPARATION

### LAYING PATTERN

Boards should be laid ‘brick bond’ fashion at 90° angles to the joist.

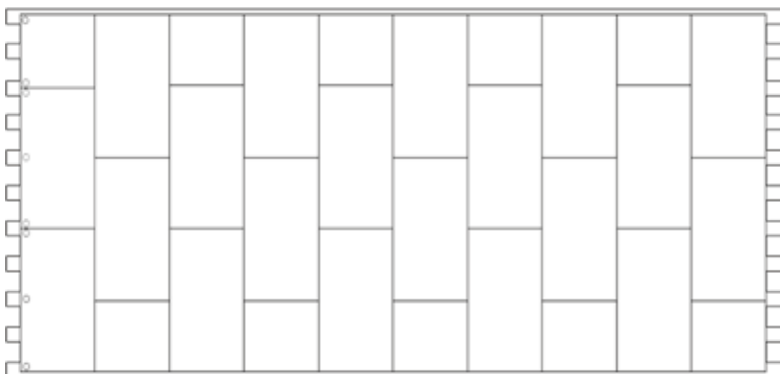

### NAILS & SCREWS

Flat headed annular grooved or ringshank nails or other improved screws have superior holding power and should be used. Panels should be fixed using corrosion resistant fasteners in service class 2. Corrosion resistant materials which include galvanized or sheradised steel, austenitic stainless steel, phosphor bronze and silicon bronze. Minimum nail or screw length should be 2.5 times the panel thickness, with a minimum nail or screw diameter of 0.16 times the panel thickness. See the table below:

Board Thickness	Nail/Screw Length	Nail/Screw Diameter
18 mm	45 mm (2.5 × panel thickness)	2.8 mm (0.16 × panel thickness)
22 mm	55 mm (2.5 × panel thickness)	3.5 mm (0.16 × panel thickness)

Screws should be countersunk, self-drilling and self tapping types. Nails should be punched and screws should be countersunk by 2 mm to 3 mm below the surface. Where floor coverings are used it is preferable not to fill the punch holes.

### JOIST CENTRES

400 mm for 18 mm boards and  
400 mm or 600 mm for 22 mm boards.

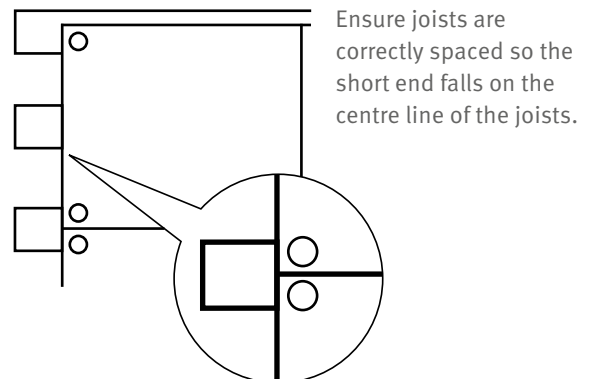



### NOGGINS

Unsupported perimeter and short end joints must be supported by a joist or noggin (including 22 mm board at 400 mm centres).

### EXPANSION GAPS

To take into account any increase of panel moisture content it is necessary to incorporate an expansion gap. For tongued and grooved panels it is essential to allow for possible expansion by providing a gap wherever boards abut any rigid upstand such as a perimeter wall/internal load-bearing walls, column, pipes or fireplace surround. The gap at each edge of the floor should be equal to 2 mm/metre run of floor but not less than 10mm wide. Movement gaps should be kept free of debris. For floors where the movement gap cannot be dealt with at the perimeter alone or which are in excess of 10 metres long e.g. corridors, intermediate movement gaps (minimum 10 mm) should be incorporated.

### ADHESIVE

EGGER D4 Adhesive is used for bonding the board to the joist and within the tongue and groove joint. It should also be used to seal nail heads and any exposed edges.

### RECOMMENDED USAGE

For bonding the board to joist and within the tongue and groove joint:

- 15 Bottles per pack of 18 mm boards (80 boards per pack)
- 12 Bottles per pack of 22 mm boards (64 boards per pack)

### GENERAL POINTS POST -LAYING

Where the board to joist bond cannot be visually identified through glue lines on either side of the joist due to insufficient adhesive having been used, we recommend fixing nails or screws through the section of floor in question.

## METHOD

### STEP ONE

Temporary bracing should be provided, in accordance with the joist manufacturers recommendations, to keep the joists in a straight and plum position.

### STEP TWO

Apply 2 continuous beads of EGGER D4 Adhesive to the length of the joist which will be covered by the first row of boards.

### STEP THREE

Place the first row of boards onto the joists and square using a line.

### STEP FOUR

Once positioned a flat headed annular grooved or ring shank nail 2.5 times the thickness of the board should be hammered flush through the board on every joist in the first row.

### STEP FIVE

As further boards are laid it will be necessary to remove the temporary bracing (Please follow your joist manufacturers recommendations). Further mechanical fixings should replace those which have been removed from the temporary bracing.

### STEP SIX

A liberal amount of EGGER D4 Adhesive should be applied directly onto the shoulder of the tongue and into the groove of the board.

### STEP SEVEN

Position board and close the joint tightly ensuring a small bead of Adhesive is forced out of the joint along the entire length of the joint on the top of the board.

### STEP EIGHT

The second and subsequent rows should be fixed with EGGER D4 Adhesive to the top of the joist (as per step 2) and steps 5-7 should be repeated. It is not recommended to glue more than one board at a time due to the rapid curing time of EGGER D4 Adhesive. Avoid walking on newly laid boards.

### STEP NINE

Seal exposed nail heads using EGGER D4 Adhesive. Perimeter edges, cut edges and stair wells should also be sealed using EGGER D4 Adhesive. Excess Adhesive is likely to foam out of the joint and form a ridge. This is to be expected and will enhance the protection of the joint. Any excess Adhesive should be left to dry and can be removed with a scraper.



[www.egger.co.uk](http://www.egger.co.uk)

## SAMPLE HOTLINE

T +44 1434 613304

F +44 1434 613302

[building.uk@egger.com](mailto:building.uk@egger.com)

**FRITZ EGGER GmbH & Co. OG**

Holzwerkstoffe

Weiberndorf 20

6380 St. Johann in Tirol

Austria

T +43 50 600-0

F +43 50 600-10111

[info-sjo@egger.com](mailto:info-sjo@egger.com)

**EGGER (UK) Limited**

Anick Grange Road

Hexham, Northumberland

NE46 4JS

United Kingdom

T +44 1434 602191

F +44 1434 605103

[building.uk@egger.com](mailto:building.uk@egger.com)